



PRS-NCO-B Network Controller



The network control unit is the heart of the Praesideo system. The unit routes up to 28 simultaneous audio channels, delivers power to the system, reports faults, and controls the system. Audio inputs can be announcements from call stations, background music, or local audio. The network control unit can be configured for the most complex public address systems. The configuration can be done comfortably and efficiently via a PC. The PC is only needed for configuration. The controller can operate independently of the PC. However, the controller can use a PC to display information on the system status using the software, supplied with the unit. The unit can be freestanding on a tabletop or mounted in a 19" rack.

Functions

Connectivity

The network controller has four analog audio inputs. Of these, two are selectable between microphone and line. The other two inputs are fixed as line inputs. The microphone/line inputs can be used as call inputs, if they are programmed conditionally to any of the eight control inputs, which are freely programmable for system actions, with freely programmable priorities.

- ▶ Public address and emergency sound system control unit
- ▶ Fully digital with four audio inputs and four audio outputs
- ▶ Control and routing of 28 audio channels
- ▶ Eight supervised control inputs and five control outputs
- ▶ Ethernet interface for configuration, control, diagnostics, and logging
- ▶ Digital storage for prerecorded messages
- ▶ Stores the last 200 fault events
- ▶ IEC60849 Certified

The controller has four analog audio line outputs each with a selectable 20 kHz monitoring signal. Three control outputs are programmable for faults or calls, and two others are used to connect visual and audible fault indicators.

Operation and performance

The network controller is completely configurable from a PC using the supplied software, which can also provide the current status of the running system, as well as comfortable and efficient configuration. The controller can also run without a connected PC, once it has been configured. The front panel has a 2 x 16-character LCD display and a rotary control to navigate through the menu and select the menu items. Address, version, fault events, and monitor enquiries can be done using the display and control knob. The network controller can control up to 60 nodes. Nodes include equipment such as power amplifiers, audio expander units, call stations, call station kits, etc.

To meet the requirements for emergency sound systems, automatic messaging is included in the network controller. The controller has a built-in, replaceable compact flash memory card, to match the storage requirements for audio messages. Four

messages can be played simultaneously. Message storage and of the messages themselves are monitored. Audio messages (as a set of wav files) can be downloaded from a computer via the Ethernet link. The controller also stores wide range of attention tones, test tones, and alarm tones, all accessible by any call stations or control inputs for announcement or alarm broadcast. An internal real time clock lets the network controller automatically do things, such as playing scheduled announcements or changing the volume of background music during evening hours. It has extensive audio processing possibilities for the audio inputs and the audio outputs. Parametric equalization, limiter and gain can be easily adjusted using the configuration software. There is a headset jack for monitoring the audio channels.

Security

The network controller supports redundant network cabling. It can be wired as a branched network or redundant loop. The system can handle 256 priorities, for calls to hundreds of zones, satisfying even the most complex public address and emergency requirements.

The controller monitors the status of all the equipment in the system, reports status changes, and stores the last 200 fault messages in the system. This monitoring extends from the capsule of a call station microphone to the end of a loudspeaker line. The external cables connected to the control inputs are monitored for short and open circuit. An internally generated pilot tone is available for monitoring the audio outputs. The controller operates both on mains power and on a 48 V battery power supply for emergency back up, with automatic switchover. It can supervise both of the power supplies.

Controls and indicators

Front

- 2 x 16-character LCD display
- Rotary/push button

Back

- Mains switch
- Voltage selector

Interconnections

Front

- Headphone output

Back

- Eight control inputs

- Two analog audio mic/line inputs
- Two analog line audio inputs
- Five control outputs (two dedicated fault)
- Four analog audio line outputs
- Ethernet
- RS232
- Two system network connections

Certifications and Approvals

Safety	acc. to IEC 60065-98
Immunity	acc. to EN 55103-2
Emissions	acc. to EN 55103-1 / FCC-47 part 15B
EVAC (TÜV certified)	acc. to IEC 60849 / BS 5839-8

Installation/Configuration Notes

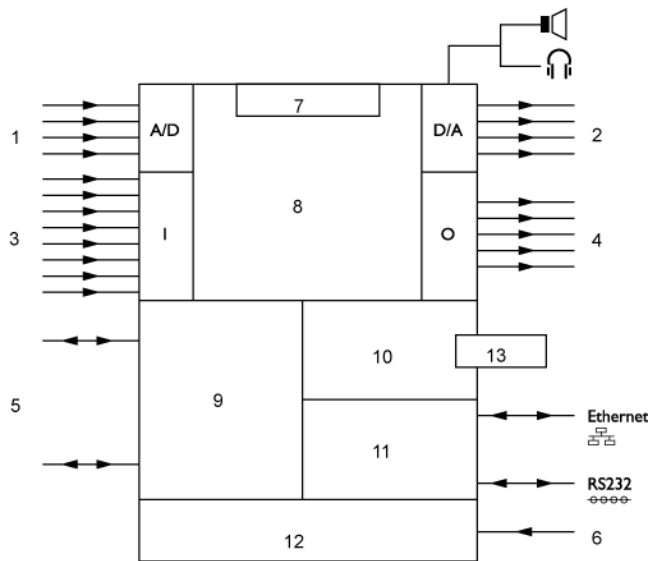

- 1 Audio inputs
- 2 Audio outputs
- 3 Control inputs
- 4 Control outputs
- 5 Plastic optical fiber network
- 6 Mains
- 7 Display and control
- 8 Network processor and DSP
- 9 Network redundancy switching
- 10 Message manager
- 11 Micro processor
- 12 Power supply
- 13 Compact flash (CF) memory card



Rear view

Parts Included

Quantity	Component
1	PRS-NCO-B Network Controller
1	Power cord
1	Set of mounting brackets for 19" rack
1	Set of feet
1	Set of connectors
1	PRS-SW Configuration, Diagnostic and Logging Software

Technical Specifications

Electrical

Mains power supply

Voltage	115/230 VAC $\pm 10\%$, 50/60 Hz
Power consumption	14 W with no load 150 W with maximum load

Battery power supply

Voltage	48 VDC -10% to +20%
---------	---------------------

Performance

Frequency response	20 Hz to 20 kHz (-3 dB)
--------------------	-------------------------

Line inputs

Connectors	2 x 3-pin XLR and stereo cinch (for each line)
S/N	>87 dBA at maximum level
CMRR	>40 dB
Input range	+18 dBV to +6 dBV (XLR) +6 dBV to -6 dBV (cinch)

Mic / line inputs

Connector	2 x 3-pin XLR
Nominal Input Level	-57 dBV
S/N	>62 dBA for dynamic range <25 dB
CMRR	>55 dB at 100 Hz
Input Impedance	1360 ohm
Phantom supply	12 V ± 1 V @ 15 mA
Input range	-7 dB to 18 dB ref nominal input level
Line outputs	4 x
Connectors	XLR and stereo cinch (for each line)
Output Impedance	<100 ohm
S/N	>89 dBA at maximum level
Crosstalk	<-85 dB
Signal range	-12 dBV to +18 dBV (XLR) -24 dBV to +6 dBV (cinch)
Distortion at 1 kHz	<0.05%

Mechanical

Dimensions (H x W x D)	
for tabletop use, with feet	92 x 440 x 400 mm (3.6 x 17.3 x 15.7 in)
for 19" rack use, with brackets	88 x 483 x 400 mm (3.5 x 19 x 15.7 in)
in front of brackets	40 mm (1.6 in)
behind brackets	360 mm (14.2 in)
Weight	7 kg
Mounting	Standalone; 19" rack
Color	Charcoal with silver

Environmental

Operating temperature	-10 to +55 °C (14 °F to +131 °F)
Storage temperature	-40 to +70 °C (-40 °F to +158 °F)
Humidity	15% to 90%
Air pressure	600 to 1100 hPa

Europe, Middle East, Africa:

Bosch Security Systems B.V.
P.O. Box 80002
5600 JB Eindhoven, The Netherlands
Phone: +31 40 27 83955
Fax: +31 40 27 86668
emea.securitysystems@bosch.com
www.boschsecurity.com

Americas:

Bosch Security Systems
130 Perinton Parkway
Fairport, New York, 14450, USA
Phone: +1 800 289 0096
Fax: +1 585 223 9180
security.sales@us.bosch.com
www.boschsecurity.us

Asia-Pacific:

Bosch Security Systems Pte Ltd
38C Jalan Pemimpin
Singapore 577180
Phone: +65 6319 3450
Fax: +65 6319 3499
apr.securitysystems@bosch.com
www.boschsecurity.com

Represented by