

AQUATEC WATER PUMPS

PERMEATE PUMPS

PAM1000 PERMEATE PUMP

Distinguishing Features:

- For membranes rated from 10 to 120 GPD
- Requires no electricity
- Pump powered by energy from brine normally lost to the drain
- Improves water quality
- Effective for inlet water pressure as low as 30 PSI
- Fills product tank up to 5 times faster under normal use
- Saves 400% of waste water vs. conventional units
- Allows smaller capacity membranes
- Increases membrane life
- Prevents "membrane TDS creep"
- Allows greater product tank pressure (90% of feed pressure)
- Compact size



PAM1000



PAMC

With its revolutionary design, the PAM1000 Permeate Pump from Aquatec performs like no other pump. Designed to operate as a non-electrical energy recovery device for typical air captive RO systems, the Permeate Pump uses the available energy from the brine water after the flow restrictor, to essentially force product water into the storage tank. This process effectively reduces the membrane back pressure to less than 5 psi, and allows the membrane to take full advantage of the available feed pressure, greatly increasing efficiency and dramatically reducing the waste water.

The Permeate Pump's advanced technology is capable of bringing the Product water holding tank up to line pressure and shutting the system down when the tank reaches full capacity. This function results in higher delivery pressure, more available water, superior water quality and extended filter and membrane life.

The Permeate Pump is effective with RO membranes rated up to 120 GPD and when combined with the 8800 series booster pump, your system will rival the production capacity of most 200 GPD commercial RO systems with a fraction of the noise level and significantly lower cost.



PAMASV

Part No.

PAM1000

Description

R.O. PERMEATE PUMP with 1/4" John Guest fittings

PAMASV

AUTOMATIC SHUT-OFF designed to work with the Permeate pump. Shuts off at 90% line pressure, versus 55% on other automatic shut-off valves. The valve has (4) 1/8" female pipe thread connections.

PAMC

HEAVY DUTY MOUNTING CLIP used to mount the permeate pump. Snaps securely in place around the pump, allowing it to be mounted to a side wall. Comes with 2 hex head screws.

PAM1000-CLIP

PERMEATE PUMP with mounting clip attached.

PAM51-107

MEMBRANE CLIP used with Permeate pump clip. Allows the pump to be mounted on the membrane vessel.

PASV2000

AUTOMATIC SHUT-OFF designed to work with the Permeate Pump and Hydro-Pneumatic storage tanks. Shuts off at 90% line pressure, versus 55%-66% on other automatic shut-off valves. This higher setting increases both the amount of water stored in the tank and the faucet flow rate. The valve has (4) 1/4" John Guest connections.

Key Benefits & Features:

- Easy to install
- Prevents TDS creep
- Positive shut-off
- Increased water in storage tank
- Increase faucet pressure/flow
- No electricity need – hydraulic operation



PASV2000

AQUATEC WATER PUMPS

PAM1000 PERMEATE PUMP

Technical Specifications:

PART NUMBER: ERP 1000

PUMP DESIGN: "Positive displacement, reciprocating, single action diaphragm, hydraulically driven
WEIGHT: 1 lb.

WETTED MATERIALS - PERMEATE SIDE: NSF listed and FDA approved thermoplastic, EPDM

NON-WETTED MATERIAL: Stainless Steel, Polypropylene

FITTINGS: 1/4" John Guest

MOUNTING: Always mount pump with outlet ports up. Mounting clip (ABS) with (2) #10 S.S. screws available.

FIGURE 1. PERMEATE PUMP DIMENSIONS

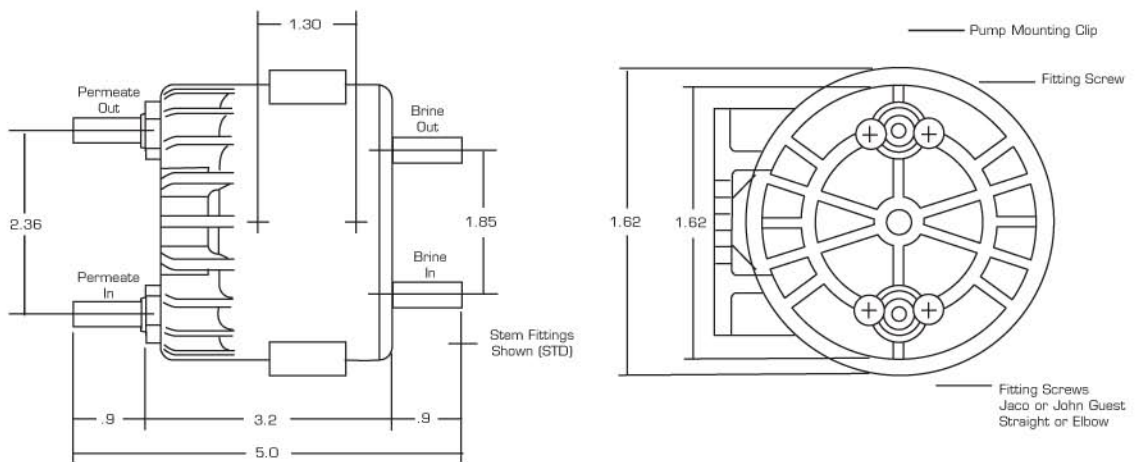

PAM1000 PERFORMANCE CURVE

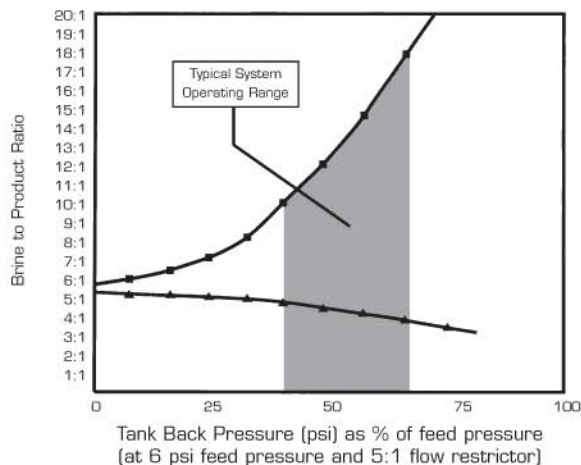

PERMEATE PUMP (PAM 1000) APPLICATIONS

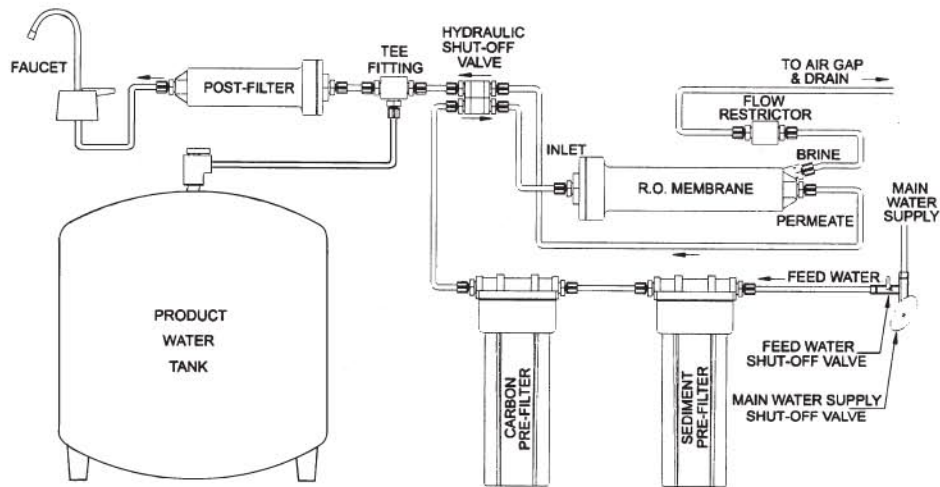

Figure 1. Typical R.O. System before installation of Permeate Pump.

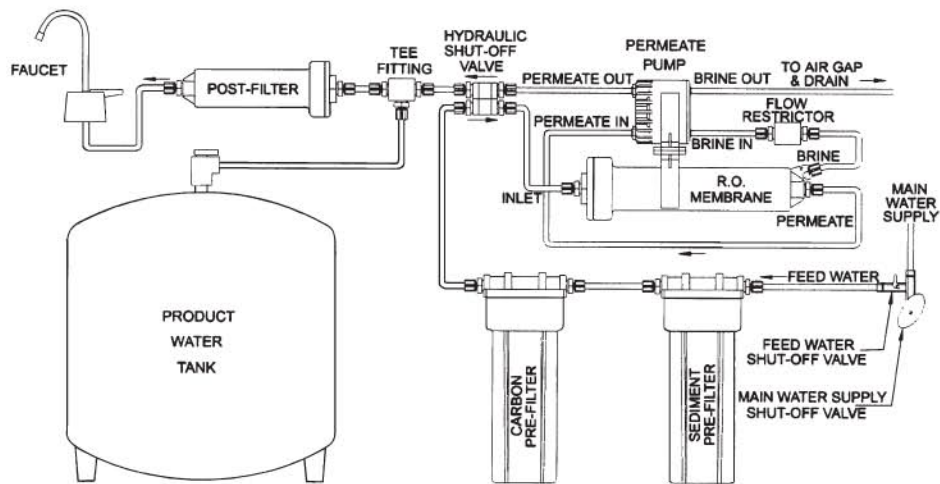

Figure 2. Typical R.O. System after installation of Permeate Pump with hydraulic shut-off valve that uses 1/8" Female pipe thread connections - **Part# PAMASV**

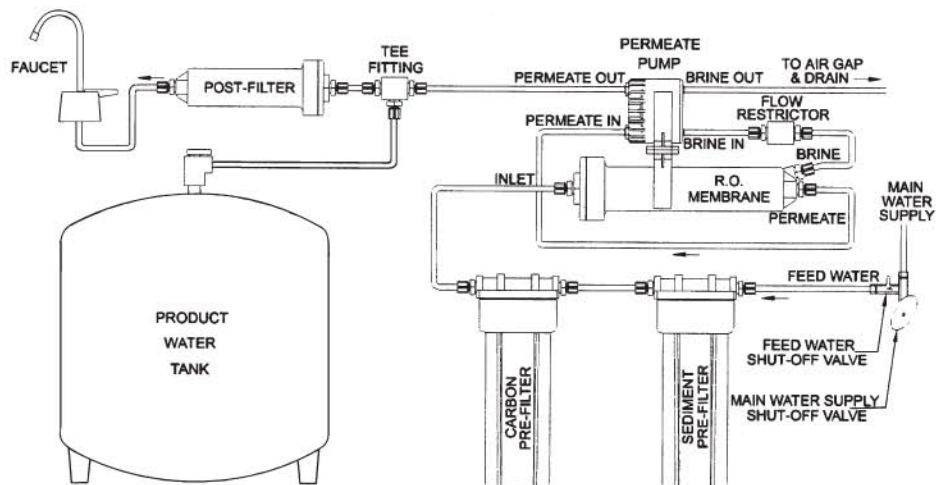

Figure 3. Typical R.O. System after installation of Permeate Pump without hydraulic shut-off valve.

PERMEATE PUMP (PAM 1000) APPLICATIONS

STANDARD RO SYSTEM WITH AUTOMATIC SHUT OFF VALVE for R.O. systems using 3/8" flexible tubing

The Permeate Pump and the Automatic Shut Off Valve are equipped with 1/4" John Guest push-to-connect fittings. These devices can be used in R.O. systems with 3/8" tubing by installing a short piece of 1/4" tubing into each of the ports that must connect with the 3/8" tubing. The line connecting the Permeate Out port to the ASV tank port will use the appropriate length of 1/4" tubing. Position the devices as shown, then cut the 3/8" tubing to fit. Attach this tubing to the short pieces extending from the ports by using John Guest Reducer Unions. The outlet ports of the Permeate pump should always be above the inlet ports in order to allow entrapped air to escape.

B.O.M.:

(1) each Permeate Pump	p/n PAM1000
(1) each Automatic Shutoff Valve	p/n PASV2000
(1) each Permeate Mounting Clip	p/n PAMC
(6) each John Guest Reducing Union	p/n J20-6-4
(6) each 1/4" tubing, 1.5" long	p/n KJ4-500 (any color)

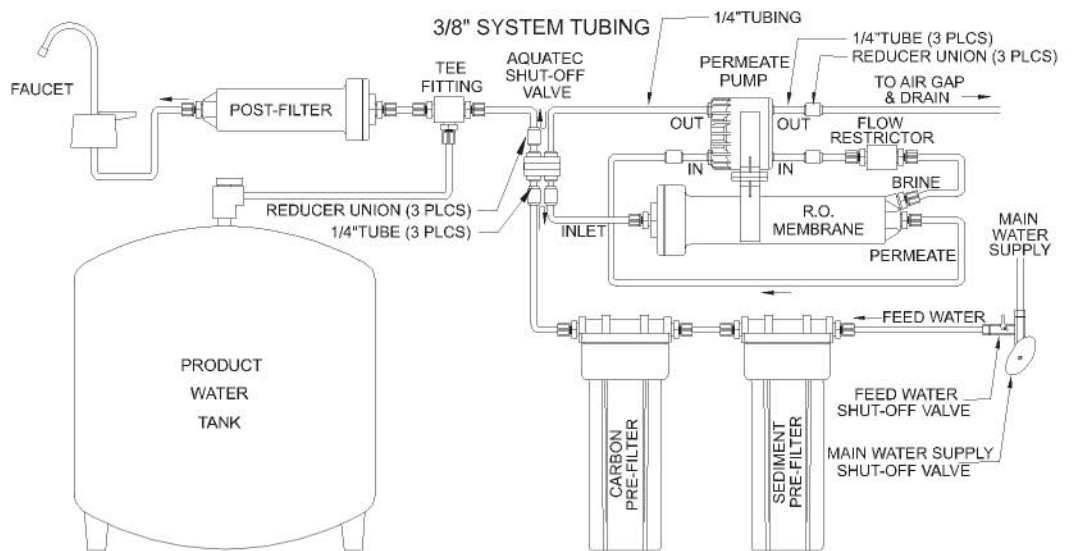

Figure 4. Typical R.O. System after installation of Permeate Pump with Aquatec shut-off valve that uses 1/4" JG connections – **Part# PASV2000**

PERMEATE PUMP PERFORMANCE

PERFORMANCE - FILL RATE @ 60 PSI FEED

PRODUCT		Time to fill	
Qty (ml)	Tank psi	With Perm	W/o Pump
4989 ml	60 psi	1hr. 13min.	
4232 ml	40 psi		1hr. 42min.
300 ml	60 psi	7min.	
1047 ml	60 psi	22.5min.	
1800 ml	40 psi		1.1hrs.

Data shown in graph above shows strong advantage of Permeate Pump in tank pressure achieved, time to completely fill the tank, and total amount of water. Permeate Pump allows 50% greater tank pressure (60 psi vs 40 psi), 18% more water (4989 ml vs 4232 ml), in 28% less time (1:13 min vs 1:42 min).

The last three lines in the chart show a significant benefit for the Permeate Pump in withdrawal of small amounts of water. A glass full (10.6 oz) takes 7 minutes to refill with a permeate system. Six cups (36.9 oz), enough for a pot of coffee is replenished in 22.5 minutes with the Permeate Pump. 1800 ml (or 63.5 oz) must be withdrawn from a conventional system to allow the hydraulic shut off valve to reopen allowing the system to refill. It takes 62 min. to replenish 1800 ml, a 176% increase in time to refill.

PERFORMANCE - FILL RATE @ 30 PSI FEED

PRODUCT		Time to fill	
Qty (ml)	Tank psi	With Perm	W/o Pump
2947 ml	24 psi	2hr. 10 min.	
2636 ml	22 psi		4hr. 41min.
300 ml	24 psi	15 min.	
1047 ml	24 psi	35 min.	
**	22 psi		4.20 hrs.

Data shown in graph above shows strong advantage of Permeate Pump for low feed water pressures. Permeate Pump allows slightly more tank pressure (24 psi vs 22 psi), 12% more water (2947 ml vs 2636 ml), in less than half the time (2:10 min vs 4:41 min). The last three lines in the chart shows a huge benefit for the Permeate Pump in withdrawal of small amounts of water. A glass full (10.6 oz) takes 15 minutes to refill with the Permeate system. Six cups (36.9 oz), enough for a pot of coffee is replenished in 35 minutes with the Permeate Pump.

No Data was taken to determine quantity that must be withdrawn from a conventional system to allow the hydraulic shut off valve to reopen allowing the system to refill, although it was observed that the product tank pressure fell 11 psi before refill commenced. It then took 4 hours 20 min. to completely refill the tank, or 800% increase in time to refill.