

**General Description**

The CSV12N50TF is the highest performance N-ch MOSFETs with specialized high voltage technology, which provide excellent RDSON and gate charge for most of the SPS, Charger ,Adapter and lighting applications .

The CSV12N50TF meet the RoHS and Green Product requirement , 100% EAS guaranteed with full function reliability approved.

**Features**

- Super Low Gate Charge
- Excellent CdV/dt effect decline
- 100% EAS Guaranteed
- Green Device Available

**Absolute Maximum Ratings**

Symbol	Parameter	Rating	Units
$V_{DS}$	Drain-Source Voltage	500	V
$V_{GS}$	Gate-Source Voltage	$\pm 30$	V
$I_D@T_C=25^\circ C$	Continuous Drain Current, $V_{GS} @ 10V^1$	12	A
$I_D@T_C=100^\circ C$	Continuous Drain Current, $V_{GS} @ 10V^1$	7	A
$I_{DM}$	Pulsed Drain Current <sup>2</sup>	36	A
EAS	Single Pulse Avalanche Energy <sup>3</sup>	190	mJ
$I_{AS}$	Avalanche Current	11.5	A
$P_D@T_C=25^\circ C$	Total Power Dissipation <sup>4</sup>	41.7	W
$T_{STG}$	Storage Temperature Range	-55 to 150	$^\circ C$
$T_J$	Operating Junction Temperature Range	-55 to 150	$^\circ C$

**Thermal Data**

Symbol	Parameter	Typ.	Max.	Unit
$R_{\theta JA}$	Thermal Resistance Junction-ambient (Steady State) <sup>1</sup>	---	62	$^\circ C/W$
$R_{\theta JC}$	Thermal Resistance Junction-Case <sup>1</sup>	---	3	$^\circ C/W$

**Product Summary**



BVDSS	RDSON	ID
500V	0.52Ω	12A

**Applications**

- High efficient switched mode power supplies
- Electronic lamp ballast
- LCD TV/ Monitor
- Adapter

**TO220F Pin Configuration**

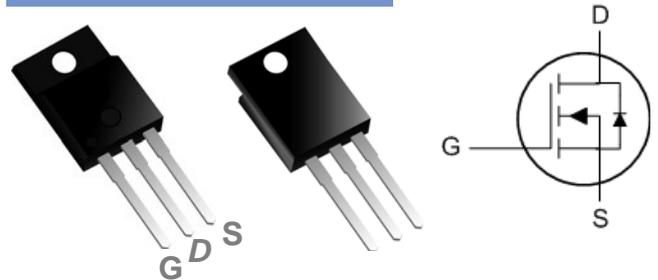

**Electrical Characteristics ( $T_J=25\text{ }^\circ\text{C}$ , unless otherwise noted)**

Symbol	Parameter	Conditions	Min.	Typ.	Max.	Unit
$BV_{DSS}$	Drain-Source Breakdown Voltage	$V_{GS}=0V, I_D=250\mu A$	500	---	---	V
$\Delta BV_{DSS}/\Delta T_J$	$BV_{DSS}$ Temperature Coefficient	Reference to $25\text{ }^\circ\text{C}$ , $I_D=1mA$	---	0.5	---	V/ $^\circ\text{C}$
$R_{DS(ON)}$	Static Drain-Source On-Resistance <sup>2</sup>	$V_{GS}=10V, I_D=4.5A$	---	0.43	0.52	$\Omega$
$V_{GS(th)}$	Gate Threshold Voltage	$V_{GS}=V_{DS}, I_D=250\mu A$	2	---	5	V
$\Delta V_{GS(th)}$	$V_{GS(th)}$ Temperature Coefficient		---	-7.7	---	mV/ $^\circ\text{C}$
$I_{DSS}$	Drain-Source Leakage Current	$V_{DS}=400V, V_{GS}=0V, T_J=25\text{ }^\circ\text{C}$	---	---	2	$\mu A$
$I_{GSS}$	Gate-Source Leakage Current	$V_{GS}=\pm 30V, V_{DS}=0V$	---	---	$\pm 100$	nA
gfs	Forward Transconductance	$V_{DS}=5V, I_D=4.5A$	---	5.5	---	S
$R_g$	Gate Resistance	$V_{DS}=0V, V_{GS}=0V, f=1MHz$	---	3.2	6.4	$\Omega$
$Q_g$	Total Gate Charge (10V)	$V_{DS}=400V, V_{GS}=10V, I_D=1A$	---	43.7	61	nC
$Q_{gs}$	Gate-Source Charge		---	11.8	16.5	
$Q_{gd}$	Gate-Drain Charge		---	12.8	17.9	
$T_{d(on)}$	Turn-On Delay Time	$V_{DD}=250V, V_{GS}=10V, R_G=10\Omega, I_D=1A$	---	23	46	ns
$T_r$	Rise Time		---	19	34	
$T_{d(off)}$	Turn-Off Delay Time		---	74	148	
$T_f$	Fall Time		---	46	92	
$C_{iss}$	Input Capacitance	$V_{DS}=25V, V_{GS}=0V, F=1MHz$	---	2375	3325	pF
$C_{oss}$	Output Capacitance		---	150	210	
$C_{rss}$	Reverse Transfer Capacitance		---	5.5	7.7	

**Guaranteed Avalanche Characteristics**

Symbol	Parameter	Conditions	Min.	Typ.	Max.	Unit
EAS	Single Pulse Avalanche Energy <sup>5</sup>	$V_{DD}=50V, L=1mH, I_{AS}=4A$	23	---	---	mJ

**Diode Characteristics**

Symbol	Parameter	Conditions	Min.	Typ.	Max.	Unit
$I_S$	Continuous Source Current <sup>1,6</sup>	$V_G=V_D=0V, \text{Force Current}$	---	---	12	A
$I_{SM}$	Pulsed Source Current <sup>2,6</sup>		---	---	36	A
$V_{SD}$	Diode Forward Voltage <sup>2</sup>	$V_{GS}=0V, I_S=1A, T_J=25\text{ }^\circ\text{C}$	---	---	1	V
$t_{rr}$	Reverse Recovery Time	$I_F=1A, di/dt=100A/\mu s, T_J=25\text{ }^\circ\text{C}$	---	165	---	nS
$Q_{rr}$	Reverse Recovery Charge		---	710	---	nC

Note :

1. The data tested by surface mounted on a 1 inch<sup>2</sup> FR-4 board with 2OZ copper.
2. The data tested by pulsed, pulse width  $\leq 300\mu s$ , duty cycle  $\leq 2\%$
3. The EAS data shows Max. rating. The test condition is  $V_{DD}=50V, V_{GS}=10V, L=1mH, I_{AS}=11.5A$
4. The power dissipation is limited by  $150\text{ }^\circ\text{C}$  junction temperature
5. The Min. value is 100% EAS tested guarantee.
6. The data is theoretically the same as  $I_D$  and  $I_{DM}$ , in real applications, should be limited by total power dissipation.

Typical Characteristics

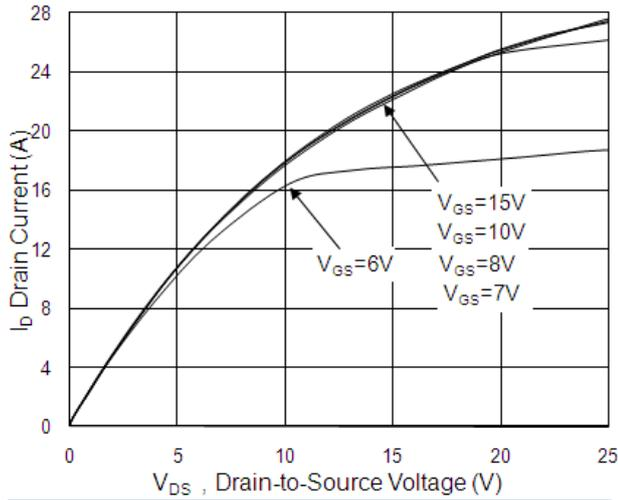

Fig.1 Typical Output Characteristics

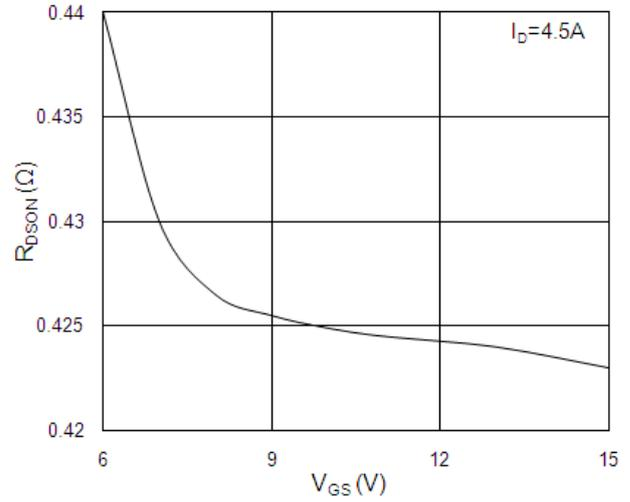

Fig.2 On-Resistance vs. G-S Voltage

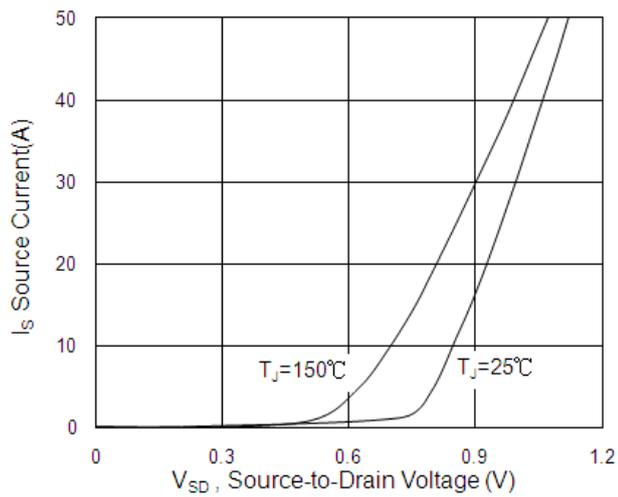

Fig.3 Forward Characteristics of Reverse

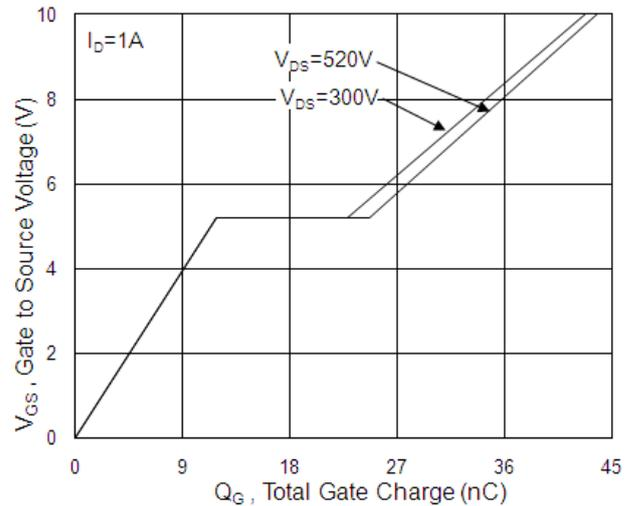

Fig.4 Gate-Charge Characteristics

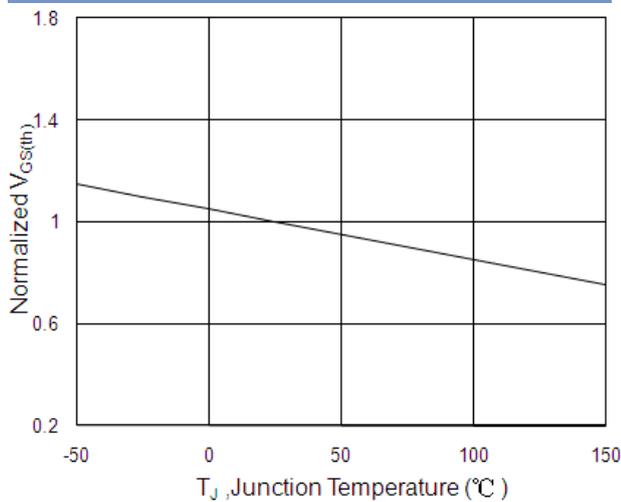

Fig.5 Normalized  $V_{GS(th)}$  vs.  $T_J$

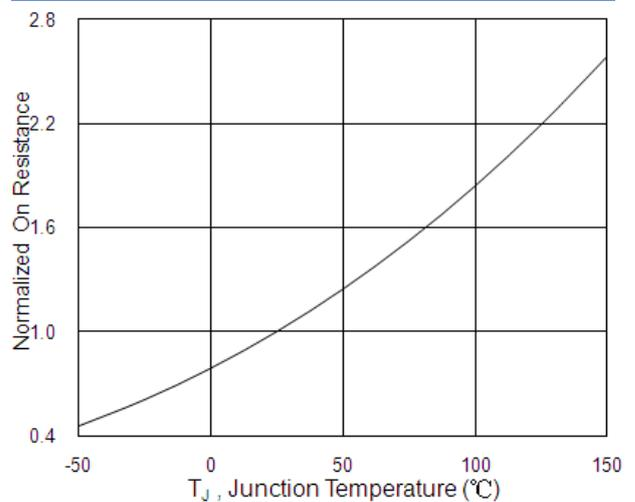

Fig.6 Normalized  $R_{DS(on)}$  vs.  $T_J$

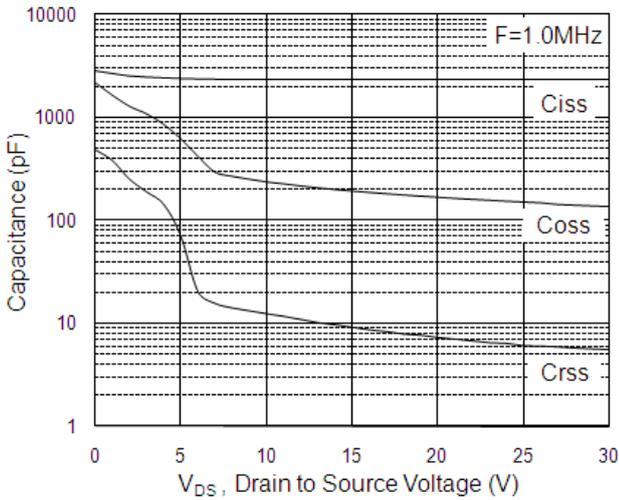

Fig.7 Capacitance

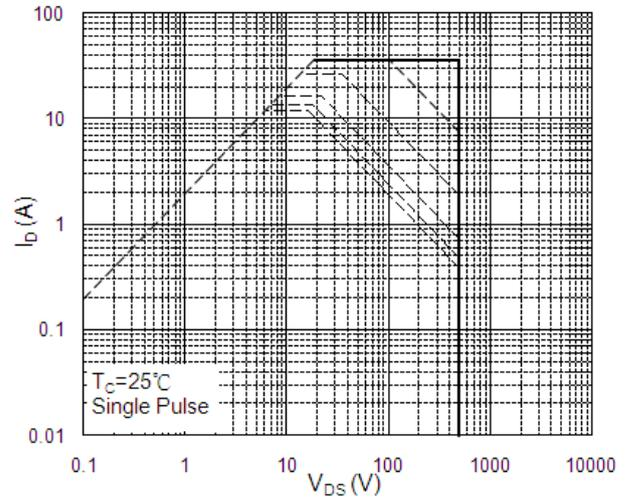

Fig.8 Safe Operating Area

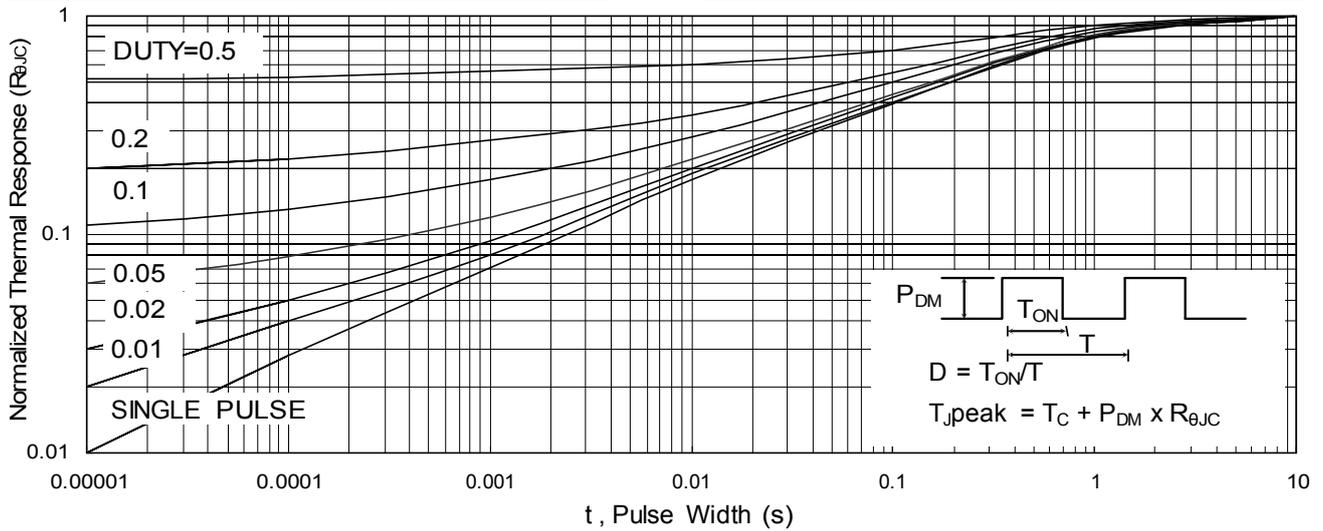

Fig.9 Normalized Maximum Transient Thermal Impedance

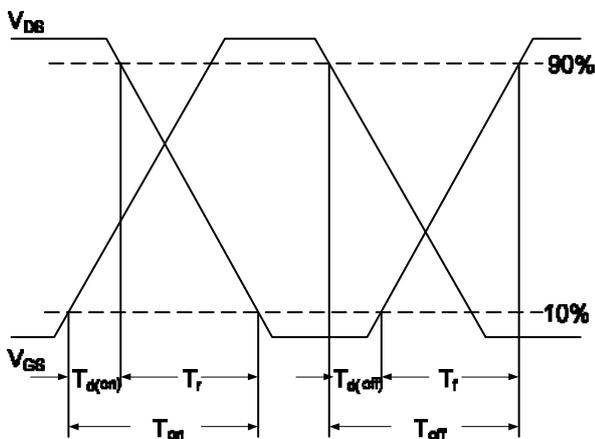

Fig.10 Switching Time Waveform

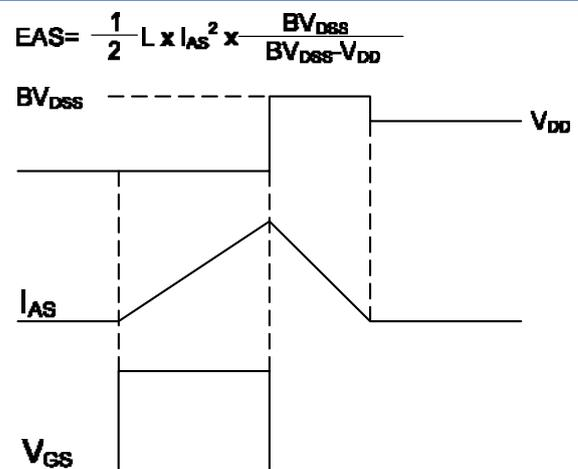

Fig.11 Unclamped Inductive Switching Waveform